

SONY®

3-CCD Color Video Camera

DXC-390 DXC-390P



The Sony DXC-390/390P is a 1/3 type DSP 3-CCD color video camera which incorporates Exwave HAD™ technology—a new Sony technology that greatly improves camera sensitivity (F8 at 2000 lx) while reducing smear. Using a C-mount lens and providing a resolution of 800 TV lines and high S/N ratio, the DXC-390/390P is ideal for applications such as microscopy, industrial inspection, and remote camera systems, where picture accuracy and detail are important. Incorporating new 10-bit DSP technology, a user friendly on-screen menu allows for simple control of various features including DynaLatitude™, Partial Enhance, and a wide selection of Automatic Exposure (AE) modes. Moreover, the DXC-390/390P is very compact [56(W) x 50(H) x 128(D)] and lightweight (370 g), making it easy to install.

ExwaveHAD™

With so many functions, the DXC-390/P is the perfect choice for a variety of applications

Microscopy

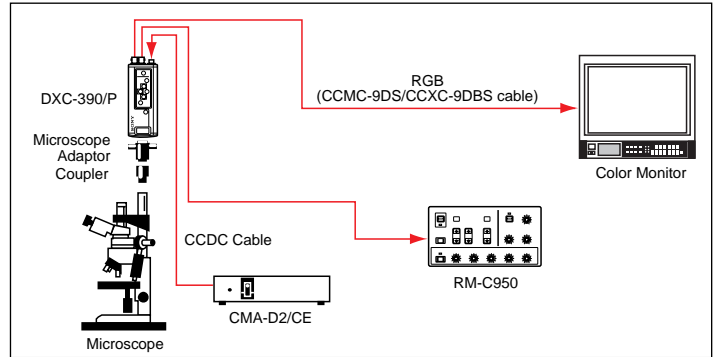

Useful DXC-390/P functions include:
 DynaLatitude, Digital Detail, Partial Enhance,
 Color Shading Compensation, Flange Back
 Adjustment

Industrial Inspection

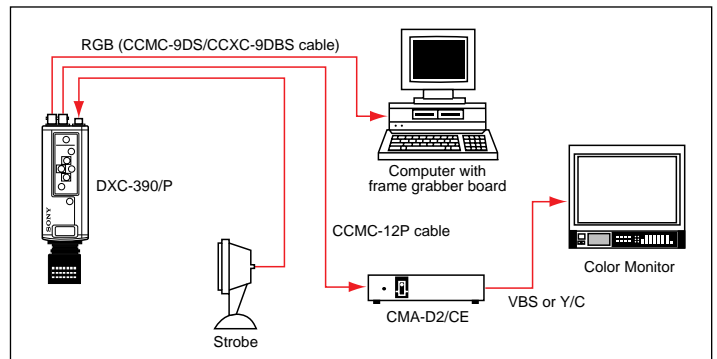
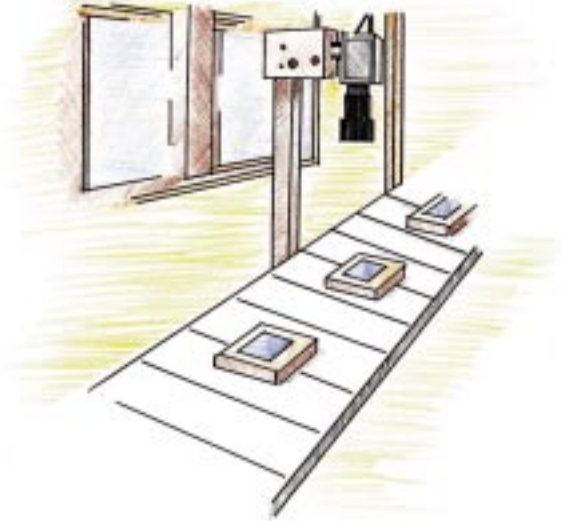

Useful DXC-390/P functions include:
 Strobe trigger function, WEN output, RGB
 sync, RS-232C Interface, Extended Genlock
 (VBS GENLOCK and HD/VD In/Out)

Remote Camera System

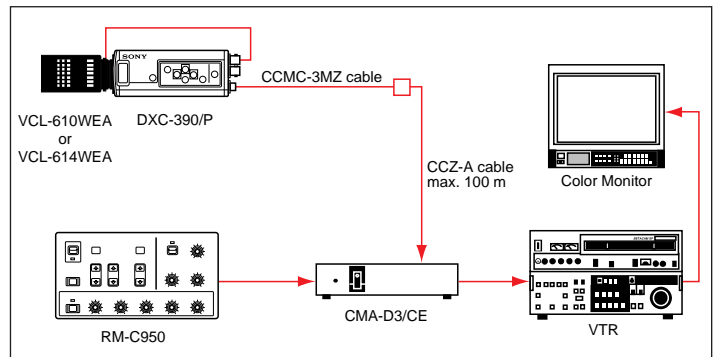

Useful DXC-390/P functions include:
 Motorized remote control lens, Selectable
 AE speed, User-defined AE area, Video
 servo auto iris lens

Features

HIGH PICTURE QUALITY

Incorporating three $\frac{1}{3}$ type IT CCDs, the DXC-390/P produces a high resolution of 800 TV lines and a high S/N ratio of 62 dB (NTSC), 61 dB (PAL). Featuring Sony's new Exwave HAD the DXC-390/P provides excellent sensitivity and low smear levels. Moreover, the DXC-390/P incorporates DSP (Digital Signal Processor) technology, resulting in images with higher picture quality and color accuracy.

DSP (DIGITAL SIGNAL PROCESSING)

The DXC-390/P incorporates new Sony 10-bit DSP technology. DSP enables a variety of enhancement features and increases picture reliability. The DXC-390/P has several DSP functions for powerful picture controls.

PICTURE CONTRAST CONTROLS

DynaLatitude

Automatically adjusts contrast corresponding to the brightness signal level of the entire image. Clear images can be captured if both bright and dark areas exist within the image.

DCC+ (Dynamic Contrast Control Plus)

Avoids hue factor distortion that can occur when subjects are very bright. DCC+ also automatically adjusts the knee point according to the contrast of the image.

Black Stretch

Black stretch/compress enhances the gradation of dark areas by stretching or compressing the range of the brightness signal in these areas.

PICTURE ENHANCE CONTROLS

Digital Detail

Adjusts the sharpness of the object outline with minimal noise. This feature also enables horizontal detail frequency control.

Linear Matrix

Enhances color reproduction by adjusting the color saturation and hue.

Partial Enhance

Enhances or softens a specific color by altering its hue, saturation and detail.

ON-SCREEN MENU

The on-screen menu feature allows for quick and easy picture adjustments while viewing the image. All camera control functions are accessible from the side panel of the camera or through the optional RM-C950.

AE (AUTOMATIC EXPOSURE)

AE automatically controls the level of brightness by varying the exposure times. This is done by combining the CCD IRIS function, AGC (Automatic Gain Control), and Auto Iris function of the lens. The DXC-390/P is equipped with a number of convenient AE modes.

AE Level

Adjusts the standard brightness level by up to +/- one F-stop in a lens iris.

AE Speed

Selectable AE (Auto Exposure) conversion speed to suit applications under varying lighting conditions.

AE Area

AE Area is a light metering system that includes six different modes.

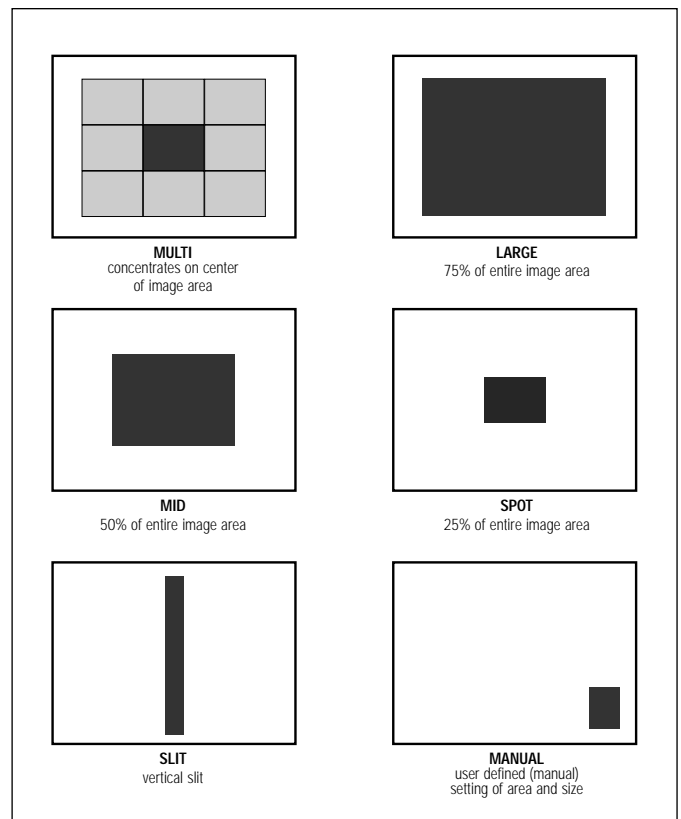

ELECTRONIC SHUTTER FUNCTIONS

Variable speeds

A variable speed electronic shutter is built into the CCD imager, making it possible to capture blur-free, clear images of high speed moving objects. The DXC-390/P features 10 different shutter speeds (OFF to 1/100,000), including flickerless mode.

Long term exposure

The shutter speed can be manually selected from 1 to 255 frames (field mode) or 2 to 256 frames (frame mode) in one-frame steps or from 0.1 to 8.0 seconds.

Clear Scan™

The Clear Scan feature eliminates the horizontal bands that appear across the screen when shooting a computer display. This is achieved by matching the camera shutter speed with the display scanning frequency.

CCD IRIS

When the level of incoming light exceeds the auto iris adjustment range, the CCD IRIS function automatically reduces the exposure in a range equivalent to 10 F-stops.

OTHER FEATURES

• Compact and lightweight

- 56(W) x 50(H) x 128(D) mm (2 1/4 x 2 x 5 1/8 inches), 370 g (13 oz)

• C mount

- extensive choice of lens

• Scene Files and User Files

- allows user to set two custom parameters in the menu for instant recall

• Hyper Gain (+30 dB)

- useful to capture images in dark conditions

• Color Shading compensation

- allows for verification of color on microscope

• RGB, Y/C and composite video outputs

• RS-232C controllable

- easy control and operation of camera by external computer

• White Balance modes

(AWB, ATW-Normal/Wide, MANU, Preset 3200K/5600K)

• Extended Genlock (VBS Genlock and HD/VD in/out)

- allows for synchronization of signals with frame grabber boards

• Synchronization capabilities (Strobe function, WEN output)

- realizes full vertical resolution of fast moving objects



DC IN/VBS OUT connector (12-pin)

Connects to the CMA-D2/CE camera adapter. DC power input and video signal output.

MENU LOCK switch

Mechanical switch protects user settings. If switch is ON, buttons on side panel are disabled.

RGB/SYNC connector (D-sub 9-pin)

RGB signals and their respective sync signals are output. CCMC-9DS/CCXC-9DBS cables are used.

TRIG IN connector (BNC)

External trigger signals input when the camera is in strobe mode.

VIDEO OUT connector (BNC)

Outputs composite video signals from the camera.

LENS connector (6-pin)

Connects to general video servo auto iris lenses or the optional VCL610WEA/VCL-614WEA zoom lenses.

REMOTE connector (mini-DIN 8-pin)

Connects to the optional RM-C950 remote control unit.

**DXC-390/P Rear Panel****DXC-390/P Side Panel**

Optional Accessories

**CMA-D3/D3CE Camera Adaptor**

- Supplies DC power and transmits video/sync signal between the adaptor and the DXC-390/P with CCZ-A cable and CCMC-3MZ cable
- Connects with optional RM-C950 remote control unit
- AC IN/DC IN
- Composite, Y/C or RGB video signal output
- Dimensions: 210(W) x 44(H) x 210(D) mm (8 3/8 x 1 3/4 x 8 3/4 inches)
- Max. cable length: 100 m with CCDC-100A cable

**CMA-D2/D2CE Camera Adaptor**

- Supplies DC power and transmits video/sync signal between the adaptor and the DXC-390/P with CCMC 12-pin multi-core cable
- Dimensions: 210 (W) x 50 (H) x 200 (D) mm (8 3/8 x 2 x 7 7/8 inches)
- Max. cable length: 25 m with CCMC-12P25 cable

**RM-C950 Remote Control Unit**

- Full remote control of the DXC-390/P camera functions and lens zoom/focus/iris functions via RS-232C
- Dimensions: 212 (W) x 41 (H) x 132 (D) mm (8 3/8 x 2 5/8 x 5 1/4 inches)

**VCL-610WEA Mount Lens****VCL-614WEA Mount Lens**

	VCL-610WEA	VCL-614WEA
Mount	1/3 type C mount	1/3 type C mount
Focal length	6.5 to 65 mm	5.5 to 77 mm
Zoom ratio	10x	14x
Zoom control	Remote	Manual/Remote switchable
Iris control	Remote	Manual/Remote switchable
Maximum aperture ratio	1.4	1.4
Minimum object distance	1.2 m	1.0 m
Macro	No	Yes
Filter thread	M 52, P=0.75 mm	M 62, P=0.75 mm
Mass	500 g	900 g

Specifications	
Pick-up device	1/3 type IT (Interline Transfer) CCD
Effective picture elements	NTSC: 768(H) x 494(V) PAL: 752(H) x 582(V)
Sensing area	6.00(H) x 4.96(V) mm
Scanning system	NTSC: 2:1 interlaced, 525 lines PAL: 2:1 interlaced, 625 lines
Horizontal frequency	NTSC: 15.734 kHz PAL: 15.625 kHz
Vertical frequency	NTSC: 60 Hz PAL: 50 Hz
Sync system	Internal or External with VBS, HD/VD
Phase control	H/ SC phase control
Horizontal resolution	800TV lines
Sensitivity	F8.0 at 2000 lx
Minimum illumination	4 lx (F2, GAIN: HYPER)
S/N ratio	NTSC: 62 dB PAL: 61 dB
Gain	STEP/ AGC/ HYPER selectable
Electronic shutter	OFF/ STEP/ VARIABLE/ CCD IRIS selectable
Lens	Remote (Auto or Manual)/ Video selectable
AE area	Multi/ Large/ Medium/ Spot/ Slit/ Manual selectable
AE level	Variable
AE speed	Fast/ Mid/ Slow selectable
AE detect	Average/ Peak selectable
Contrast Effect	Manual/ DynaLatitude/ DCC+ selectable
Knee Point	High/ Normal/ Low selectable (Contrast Effect: Manual)
Black stretch	Variable (Contrast Effect: Manual)
Gamma	ON/ OFF Variable
Pedestal	Master and R/B Manual adjustable
Black balance	ABB
White balance	AWB/ ATW NORMAL/ ATW WIDE/ MANUAL/ 3200K/ 5600K selectable AWB or ATW R/B Paint, MANUAL R/B Gain
ATW area	NORMAL/ MANU selectable
ATW speed	FAST/ NORMAL/ SLOW selectable
Detail level	ON/ OFF (Variable at ON)
Detail Frequency	HIGH/ MID/ LOW selectable
Linear matrix	ON/ OFF
Linear matrix MODE	STANDARD/ R Enhance/ G Enhance/ B Enhance/ Manual selectable
Partial Enhance	ALL/ IN/ OUT selectable
CCD integration mode	FIELD/ FRAME selectable
Shading Compensation	OFF / ON (Manual control)
Trigger Polarity	Positive edge trigger / Negative edge trigger selectable
Baud rate	19200/ 9600/ 4800/ 2400/ 1200 selectable
Sync	RGB/ G/ OFF selectable
Strobe	ON/ OFF

User File	A/ B switchable (Two pattern memories)
Scene File	STANDARD/ MICROSCOPE/ FULL AUTO/ STROBE/FILE A or B
Output signal	VBS/RGB/SYNC/Y/C
Operating temperature	-5°C to 45°C
Storage temperature	-20°C to 60°C
Power requirements	DC 10.5 V to 15.0 V
Power consumption	Approx. 7.6 W
Dimensions	56(W) x 50(H) x 128(D) mm (2 1/4 x 2 x 5 1/8 inches) (Excluding projecting parts)
Mass	Approx. 370 g (13 oz)
Connectors	Lens (6 pin) RGB/SYNC (9 pin D-sub) DC IN/VBS (12 pin) VIDEO OUT (BNC) TRIGGER IN (BNC) REMOTE (8 pin mini DIN)

Supplied accessories	
	Lens cap (1) Tripod adapter (1) Operation manual (1) Panel sheet for RM-C950

Optional accessories	
Lens	VCL-610WEA/614WEA VCL-08WMM/16WMM/25WMM
Remote control unit	RM-C950
Camera adapter	CMA-D2/ CE, CMA-D3/ CE
Microscope adapter	MVA-15
Microscope coupler	MVAC-33-N/33-O/33-SM
Camera cable	CCDC-5/10/25/50A/100A CCMC-12P02/05/10/25 CCXC-9DBS CCMC-9DS CCMC-3MZ CCZ-A2/A5/A10/A25/A50/A100

DXC-390/DXC-390P Connector Pin Assignments

6-pin

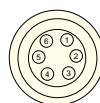

1	FOCUS CONTROL
2	ZOOM CONTROL
3	DC OUT (G)
4	IRIS CLOSE
5	IRIS CONROL/VIDEO OUT
6	DC OUT (+)

8-pin

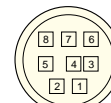

1	INTER CONNECT
2	INTER CONNECT
3	DATA OUT
4	DC OUT (G)
5	DATA IN
6	NC
7	DATA OUT (+)
8	CMA DATA

9-pin



1	VBS/Y OUT (G)
2	RGB OUT (G)
3	R OUT (X)
4	G OUT (X)
5	B OUT (X)
6	VBS/Y OUT (X)
7	C.SYNC/WEN OUT (X)
8	C.SYNC/WEN OUT (G)
9	-/C OUT (X)

12-pin

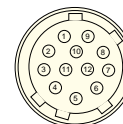

1	DC IN (G)
2	DC IN (+)
3	VBS/Y OUT (G)
4	VBS/Y OUT (X)
5	HD IN/OUT (G)
6	HD IN/OUT (X)
7	VBS/VD IN C.SYNC/VD OUT (X)
8	-/C OUT (G)
9	-/C OUT (X)
10	DC IN (G)
11	DC IN (+)
12	VBS/VD IN C.SYNC/VD OUT (G)

Dimensions

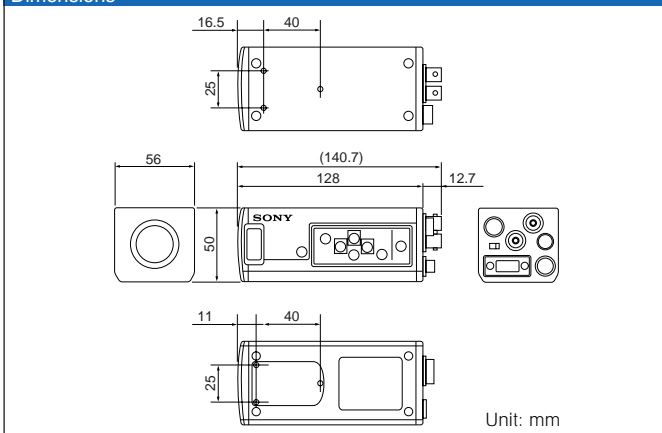

Distributed by