

PULNiX

TMC-1000



Applications

- Color Machine Vision Inspection
- High-Resolution Surveillance
- High-Definition Graphics Inspection
- Agricultural Products Inspection

General Description

The PULNiX TMC-1000 is a 1K x 1K pixels resolution progressive scan color camera with asynchronous reset capability. The interline transfer CCD imager, in combination with the Bayer Color Filter Array (CFA), offers excellent resolution and color fidelity. Progressive scanning permits a full frame of image resolution per shutter or integration. This feature offers significant advantage over TV-format interlace color cameras, including 3-chip color cameras. The camera also has excellent electronic shutter capability.

The camera features an RGB analog video output. It also features a Channel Link™* (LVDS) digital output that is in a 24-bit RGB format. Channel Link is a transmitter/receiver chipset pair designed for flat-panel display technologies. It is well suited for digital video transmission and offers two main advantages: smaller cables and faster data rates. Visit PULNiX's website at www.pulnix.com for information on Channel Link-compatible frame grabbers. Color interpolation is implemented by PULNiX's proprietary Digital Signal Processor (DSP) that is controlled by RS-232C communication. This allows remote adjustments to the color matrix, white balance, gain, and edge enhancement. The camera features four memory banks that store camera control parameters. The first two banks, Bank1 and Bank2, can be selected via a switch on the back panel of the camera. Bank3 and Bank4 can be selected via RS-232C control. This feature allows easy switching between different camera-control parameters as application requirements change.

Graphical User Interface

All signal processing is controlled by digital calculations within the camera. The color matrix generates a high level of consistency for the most critical and demanding industrial applications. The color matrix coefficients are externally controllable via the RS-232C control. PULNiX offers a simple graphical interface that allows basic function control.



PULNiX's proprietary DSP chip

Product Features

- 1" progressive scan CCD imager
- 1008H x 1018V pixels resolution
- Bayer RGB color filter array (CFA)
- Full digital processing using realtime proprietary DSP
- Progressive scan output in 24-bit LVDS Channel Link™ digital and RGB analog output
- Built-in YCrCb 4:4:4 and 4:2:2 converter
- Full frame shutter, 1/15 to 1/16,000 sec.
- Asynchronous reset with external shutter control
- External sync control
- Full frame integration
- RS-232C control

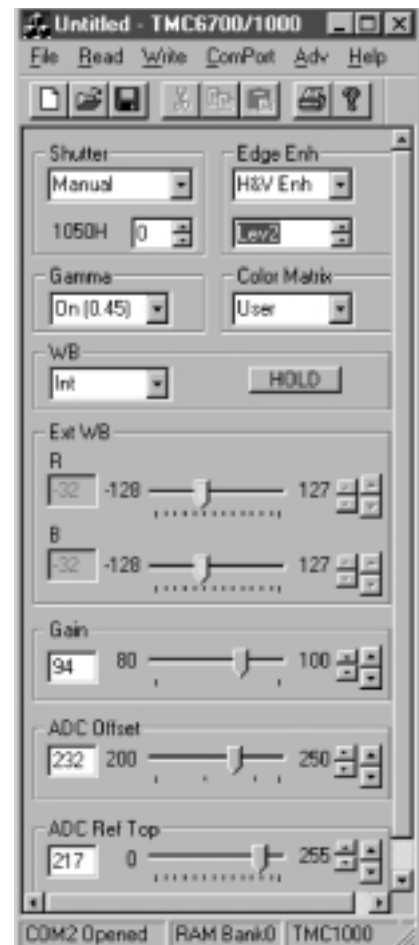

TMC-1000

*Channel Link™ is a National Semiconductor trademark

TMC-1000 Progressive Scan CCD Digital Color Camera

Asynchronous Reset

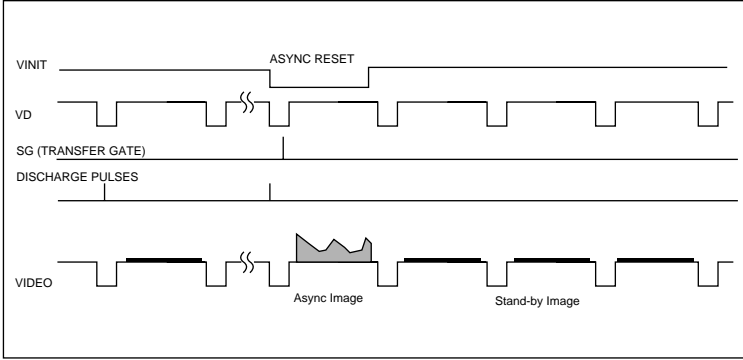

The TMC-1000 asynchronous reset operates with internal sync or external HD for phase locking. When VINIT pulse is applied, it resets the camera's scanning and purges the CCD.

There are three modes to control the asynchronous reset and shutter speed.

1. External VINIT with pulse width control. The pulse width between two pulse edges controls the shutter speed externally from 1/16,000 sec. to 4 sec.
2. Internal shutter speed with fast mode. The video signal has no delay from the reset timing. The shutter speed range is 1/2,000 to 1/16,000 sec.
3. Internal shutter speed with slow mode. The speed control is variable from 1/15 to 1/1,750 sec. The video signal starts with internal V reset timing related to shutter speed.

Bayer Primary Color Filter

The TMC-1000 employs a color filter array (CFA) called a "Bayer CFA" which comprises a ratio of two green pixels to one red or blue pixel. The color interpolation is implemented by digital signal processing developed by PULNiX.

Bayer Color Filter Array

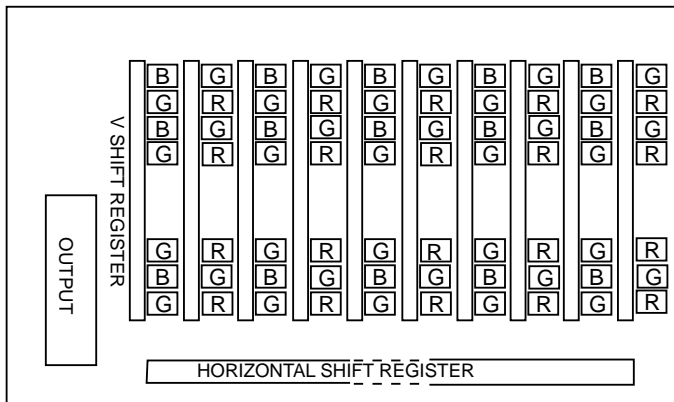

Electronic Shutter

The TMC-1000 has a substrate drain shutter mechanism which provides a superb picture at various speeds without smearing. Progressive scanning permits 1016 lines (2 lines less than the imager) of full vertical resolution per single shutter. The manual shutter-speed control selects the electronic shutter rate of 1/15 to 1/16,000 sec. The user can assign any shutter speed to any of the preset shutter positions. The factory default values are as follows:

SHUTTER

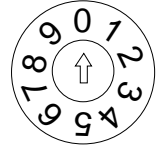

Shutter Control Switch

Switch Position	Manual (MAN)	Async (ASY)
0	no shutter	no shutter
1	256H 1/60	1.0H 1/16,000
2	128H 1/125	2.0H 1/8,000
3	64H 1/250	4.0H 1/4,000
4	32H 1/500	8.0H 1/2,000
5	16H 1/1,000	16H 1/1,000
6	8H 1/2,000	32H 1/500
7	4H 1/4,000	64H 1/250
8	2H 1/8,000	128H 1/125
9	1H 1/16,000	Pulse width control

The asynchronous shutter is activated by selecting async reset and the shutter speed. The async reset pulse, VINIT, must be applied to set up the shutter. With VINIT high (5V), the CCD keeps discharging. With a negative going pulse to VINIT, the camera resets and purges the charge momentarily. Then it starts integrating for the period of shutter control set either by internal shutter control or external pulse width control. If "0" shutter is selected in async mode, the camera resets asynchronously without shutter function; this can be used for applications requiring strobe lighting.

Integration

The CCD imager of the TMC-1000 can be exposed for longer than 1 frame timing (1/15 sec.) This feature provides high sensitivity for low light applications. Integration is achieved by controlling the #11 pin of the 12-pin connector to Low (GND). Integration also can be achieved by VINIT pulse width control of the async shutter up to four seconds.

TMC-1000 Progressive Scan CCD Digital Color Camera

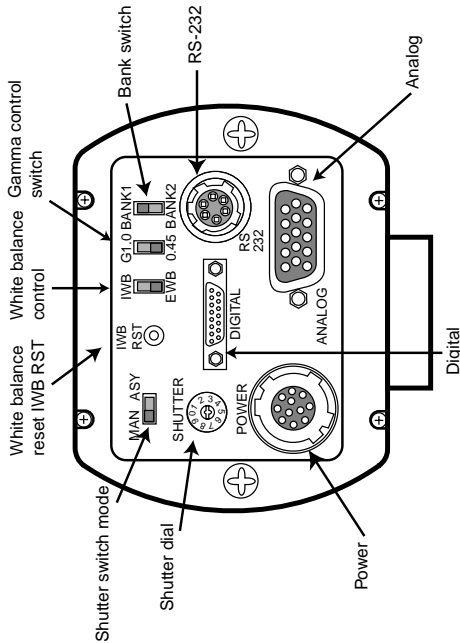
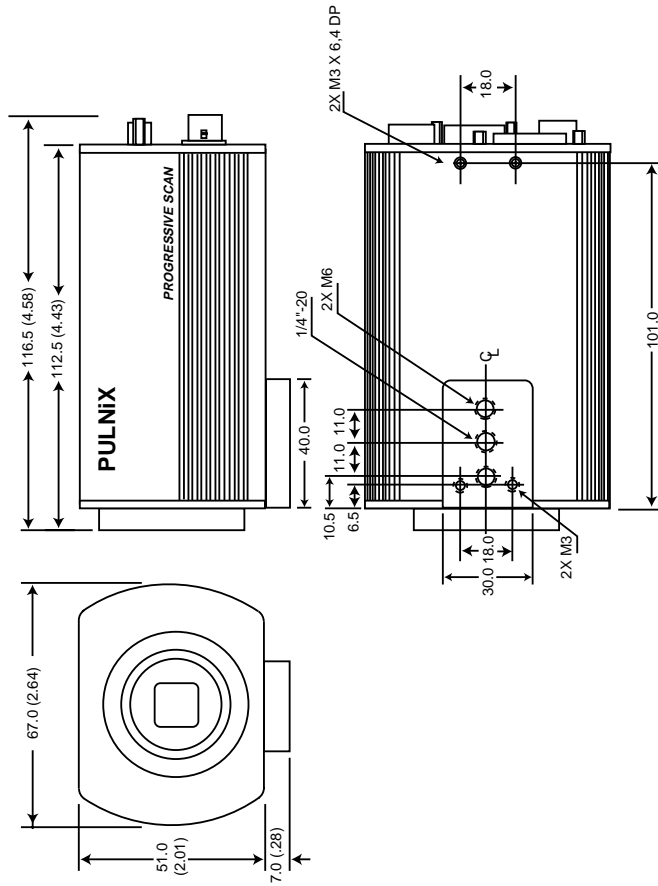

Switch	Mode	Description	Action
Shutter Dial	0 to 9 positions Manual mode (MAN)	Shutter speed control dial for manual shutter mode	Please refer to the Shutter Control Switch Diagram
	0 to 9 positions Asynchronous Reset Mode (ASY)	Shutter speed control dial for asynchronous shutter mode	
Shutter Mode Switch	MAN	Manual shutter mode	Camera continuously outputs video at 15FPS
	ASY	Asynchronous Shutter mode	Camera resets on Vinit signal: pin 6 of 12-pin connector
White Balance Reset IWB RST	Held down	White Balance Reset omits	Calibrates the white balance so that the selected object appears to be white.
	Released		Camera maintains the last white balance values.
White Balance Control	IWB	Internal White Balance	Selects Internal White Balance mode
	EWB	External White Balance	Selects External White Balance mode. EWB preset values can be changed via RS-232C only.
Gamma Control Switch	G1.0	Gamma 1.0	Selects Gamma 1.0
	G0.45	Gamma 0.45	Selects Gamma 0.45
Bank Switch	Bank1	Bank1 Selection switch	Selects Bank1 camera parameter set.
	Bank2	Bank2 Selection switch	Selects Bank2 camera parameter set. NOTE: Bank3 and Bank4 can be selected via RS-232C control.

Connector	Type	Cable Needed	Cable Information
RS-232	6-pin female connector	CBL-RS232-C9	Connect a PC to the camera using the RS-232C control cable (CBL-RS232-C9). This cable is a part of the communication kit (CS-232C)
Analog	15-pin High Density D-sub female connector	CBL-2R-15	If you are using a monitor or frame grabber that needs Red, Green, Blue, Vertical Sync, and Horizontal Sync, then use the RGB analog cable (CBL-2R-15).
Digital	15-pin female AirBorn connector	15CL-02 or 15CL-02-15	Use the Channel Link™/TTL adapter cable if you are using a non-Channel Link frame grabber that needs TTL input. Use the Direct Channel Link cable (15CL-02-15) if you are using a Channel Link frame grabber.
Power/Sync	12-pin Hirose male connector	12P-02S or PD-12UU series power supply	Connect a 12V DC power supply (K25-12V or PD-12UU series) using power cable 12P-02S (also includes external signals such as Vd, Hd, and VINIT) or connect power supply PD-12UUP.

SPECIFICATIONS

Imager	1" progressive scan interline transfer CCD with Bayer Primary RGB color filter
Active Area	9.1mm x 9.2mm
Active Pixel	1008 (H) x 1018 (V)
Cell size	9.0 μm x 9.0 μm
Display Modes (Active Pixels)	1008 (H) x 1018 (V) @ 15 Hz 1008 (H) x 509 (V) @ 30 Hz (two row binning)
Sync	Internal/external auto switch HD/VD, 4.0 Vp-p impedance 4.7KΩ VD = 15Hz ±5%, non-interlace HD = 15.75KHz ±3%
Data clock output	20.034 MHz
S/N ratio	50dB min., 56dB typical
Min. illumination	3.5 lux, f-1.4 (AGC off), Sensitivity: 10μV/e-
Video output	Digital: 24-bit RGB format with Channel Link™ (LVDS) output* Analog: 0.66 Vp-p 75Ω RGB video
Gain	User controllable (3 to 28 dB)
Gamma	.45 (default) or 1.0 selectable

Lens mount	C-mount
Power req.	12V DC, 450 ±50 mA
Operating temp	-10°C to 50°C
Vibration	Random, 7 G rms, 10-2000Hz
Shock	70G, 500mS half-sine
Size (W x H x L)	51mm x 67mm x 116.5mm 2.01" x 2.64" x 4.58"
Weight	374 grams (13.2 oz) without tripod mount
Functional options	

Optional accessories	(must be ordered separately)
I/O cables	RGB cable: CBL-2R-15 (analog) Channel Link/TTL Adapter cable: 15CL-02 Direct Channel Link cable: 15CL-02-5 12P-02S
Power cable	K25-12, K50-12, PD-12UUP series
Power supply	Power supply for 15CL-02-15: PD-5
Kits	RS-232C controller set: CS-232C

Pin Configurations

12-Pin Connector

Pin	TMC-1000	12P-02S Cable
1	GND	Gray
2	+12V DC IN	Yellow
3	GND	Red Shield
4	N/C	Red Coax Signal
5	GND	Orange Shield
6	VINIT	Orange Coax Shield
7	VD IN	Black Coax Signal
8	GND	White Shield
9	HD IN	White Coax Signal
10	N/C	Brown
11	INTEG CONT	Blue
12	GND	Black Shield

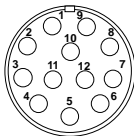

15-Pin Connector

AirBorn: MP221-015-243-2200

Pin#	Description	Pin#	Description	Pin#	Description
1	CH CLK+	7	D_INTEG+	13	CH3-
2	CH0+	8	GND	14	D_VINIT-
3	CH1+	9	CH CLK-	15	D_INTEG-
4	CH2+	10	CH0-		
5	CH3+	11	CH1-		
6	D_VINIT+	12	CH2-		

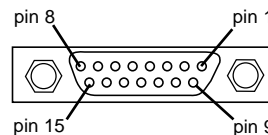

6-Pin Connector

The TMC-1000 has a 6-pin connector for RS-232C communication. A mating 6-pin connector (PC-6P) can be obtained from PULNiX.

Pin #	Description	Pin #	Description
1	RS-232 RX	4	GND
2	RS-232 TX	5	GND
3	reserved	6	GND

Note: CH** : LVDS Channel Link™ output D_VINIT, D_INTEG: LVDS input for camera control

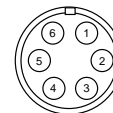

15-Pin SVGA Output Connector

Pin#	Description	Pin#	Description
1	Red	9	N/C
2	Green	10	N/C
3	Blue	11	GND
4	GND	12	N/C
5	GND	13	H Sync
6	Red GND	14	V Sync
7	Green GND	15	N/C
8	Blue GND		

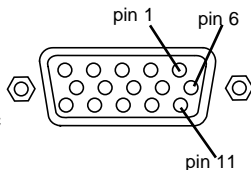

*Channel Link™ is a National Semiconductor trademark



PULNiX

Innovation at work!

PULNiX America, Inc. Tel: 408-747-0300
1330 Orleans Drive Tel: 800-445-5444
Sunnyvale, CA 94089 Fax: 408-747-0660