

Camera Link is a new digital transmission method, designed by vision product manufacturers specifically for the machine vision industry, in answer to customer requests. It is an easy way to connect digital cameras to frame grabbers.

Camera Link is a camera-to-frame grabber interface specification based on an implementation of Channel Link™ technology. It includes hardware (cable connectors), & data transmission as well as camera control and asynchronous serial communications all on a single cable. Now, only two connections (power and Camera Link) are required to operate the camera.

The specification was developed through an initiative headed by PULNiX America, Inc. Camera Link defines a single connector for both the frame grabber and the camera. This insures that all products bearing the Camera Link logo are interchangeable with each other. The official Camera Link logo is shown to the right.

As a standard that has been defined by industry members, Camera Link provides the following benefits:

- **Real-time signaling:** Camera Link supports real-time signaling. Camera Link cameras accept signals including asynchronous reset (Vinit), HD, VD, and integration through the Camera Link cable, without latency (delay).
- **High data rates:** A base configuration Camera Link interface can handle 1.2Gbps of data. The technology used in Camera Link has a maximum data rate of 3.5Gbps, insuring solutions for tomorrow's applications.
- **Flexibility:** Camera Link is independent of imager resolution, video format, and frame rate. In contrast, some other digital transmission standards are set for specific pre-defined video formats.
- **Platform Independence:** Camera Link is a hardware specification designed by camera and frame grabber manufacturers specifically for the Machine Vision industry. The frame grabber software must be Windows™ 9X/2000 compatible, but is independent of support from third parties like Microsoft, Apple, or Intel.



*Camera Link™ is a registered copymark of the AIA*

- **Simple interface:** Only two connections are required to interface a camera and frame grabber: Power and Camera Link. Cameras and frame grabbers can be easily interchanged using the same cable.
- **Standardized cable assembly:** Camera Link specifies a standard cable assembly. This eliminates the need for manufacturers to provide custom cables, and allows customers to take advantage of lower cable prices. In addition, the technology used in Camera Link reduces the number of wires required to transmit data, allowing for thinner cables, which are more robust and less prone to breakage. Various cable lengths are available up to 10m.
- **Extensive application software support from frame grabber and vision software companies:** Machine vision applications require robust and field-proven software. Camera Link is a quick and simple way for users to standardize their systems for existing applications without having to verify new software.
- **Long-term, stable supply:** Channel Link technology is committed to providing long-term support to the telecommunications industry. Unlike most consumer products, the basic architecture will remain stable for many years to come.



*Channel Link™ is a registered trademark of National Semiconductor.*

*Windows 2000™ is a registered trademark of Microsoft Corporation.*

# PULNiX Camera Link Cameras

## Channel Link Technology

The heart of Camera Link is Channel Link, a data transmission method by National Semiconductor. Channel Link is made up of a receiver chip and a transmitter chip. This chipset is used to transmit digital data. This technology offers many advantages to machine-vision applications over the previous method, namely, RS-644 (LVDS format of RS-422).

LVDS (Low Voltage Differential Signaling) has become the most common means to transmit digital data in recent years. This method, however, has several major drawbacks. LVDS requires a pair of wires for transmission of each data bit, creating bulky cables prone to breakage if stressed. Also, the maximum data transmission rate of LVDS is 400 Mbps, fast enough for today's applications, but limiting for tomorrow's requirements. Channel Link takes LVDS to the next level.

Channel Link uses LVDS standards to transmit data. Far fewer wires, however, are needed to transmit the data. A Channel Link transmitter will convert 28 bits of data into a format that can be transmitted over 4 parallel lines. A transmit clock over a fifth line finishes the requirements for Channel Link transmission. The diagram to the right shows how just five pairs of wire are able to transmit data that would require 56 wires using standard LVDS methods.

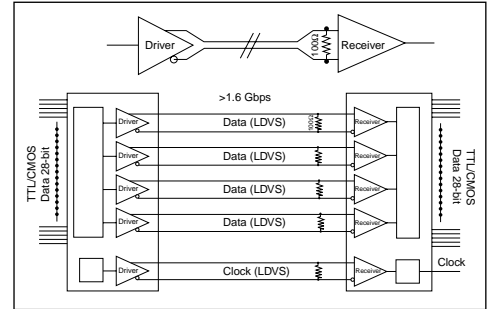

## Camera Link Connector and Cable Configurations

A single Camera Link connection provides the following information on an MDR connector with 26 pins.

Image data and timing	4 pairs
	1 pair transmission clock
Serial communication	1 pair transmit
	1 pair receive
Camera Control	4 signal pairs

This configuration will transfer up to 28 bits of data. For applications that require more bandwidth, additional Camera Link connections can be used.

There are 3 configurations – base, medium and full. Please visit the PULNiX web site for detailed specifications of Camera Link.

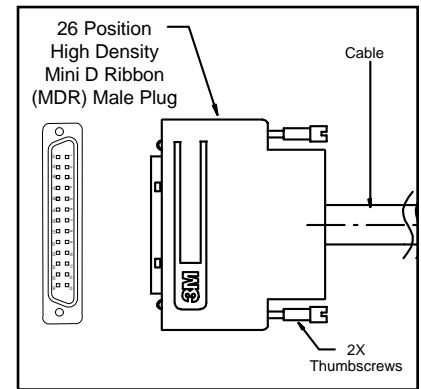

Camera Link Cable

**Note:** The MDR-26 cable assembly is manufactured by 3M Corporation.

## Camera Link Cable Ordering Information

Camera Link cables are available from multiple vendors.

PULNiX P/N	3M	Intercon I	Length
<b>Molded Cables</b>			
26CL-01-26*	I4T26-SZLB-100-0LC	CLCP-1.0-p	1.0 m
26CL-02-26	I4T26-SZLB-200-0LC	CLCP-2.0-p	2.0 m
26CL-03-26*	I4T26-SZLB-300-0LC	CLCP-3.0-p	3.0 m
26CL-05-26	I4T26-SZLB-500-0LC	CLCP-5.0-p	5.0 m
26CL-07-26*	I4T26-SZLB-700-0LC	CLCP-7.0-p	7.0 m
26CL-10-26	I4T26-SZLB-A00-0LC	CLCP-10-p	10.0 m
	I4T26-SZLB-450-0LC	CLCP-4.5-p	4.5 m
<b>Shell Kit Cables</b>			
	I4B26-SZLB-100-0LC	CLCPH-1.0-p	1.0 m
	I4B26-SZLB-200-0LC	CLCPH-2.0-p	2.0 m
	I4B26-SZLB-300-0LC	CLCPH-3.0-p	3.0 m
	I4B26-SZLB-450-0LC	CLCPH-4.5-p	4.5 m
	I4B26-SZLB-500-0LC	CLCPH-5.0-p	5.0 m
	I4B26-SZLB-700-0LC	CLCPH-7.0-p	7.0 m
	I4B26-SZLB-A00-0LC	CLCPH-10-p	10.0 m

\* non standard stock items

# PULNiX Camera Link Cameras

## Connector and Pin Configurations

### Camera Link Connector (MDR 26-pin connector)

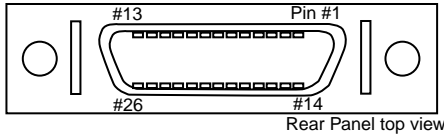

TMC-6700CL/TMC-1000CL      AccuPiXEL™ Series

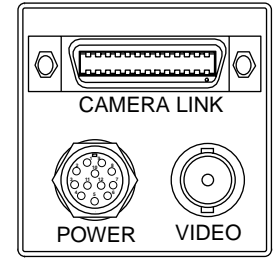
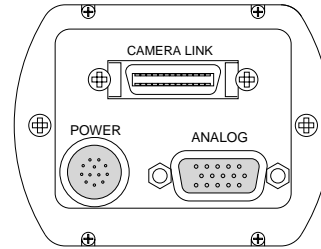

### MDR 26-pin connector 10226-6212VC

Pin#	Description	I/O
1	GND (shield)	
2	X0- (CH0-)	Out
3	X1- (CH1-)	Out
4	X2- (CH2-)	Out
5	Xclk- (CLK-)	Out
6	X3- (CH3-)	Out
7	SerTC+ (Rx+)	In
8	SerTFG- (Tx-)	Out
9	CC1- (Vinit/VD-)	In
10	CC2+ (Integ/ROI+)	In
11	CC3- (HD-)	In*
12	CC4+ (RCLK+)	In**
13	GND	
14	GND (shield)	
15	X0+ (CH0+)	Out
16	X1+ (CH1+)	Out
17	X2+ (CH2+)	Out
18	Xclk+ (CLK+)	Out
19	X3+ (CH3+)	Out
20	SerTC- (Rx-)	In (LVDS or RS-232)
21	SerTFG+ (Tx+)	Out
22	CC1+ (Vinit/VD+)	In
23	CC2- (Integ/ROI-)	In
24	CC3+ (HD+)	In*
25	CC4- (RCLK-)	In**
26	Inner shield	

### The 26-pin connector pin assignment (Camera Side)

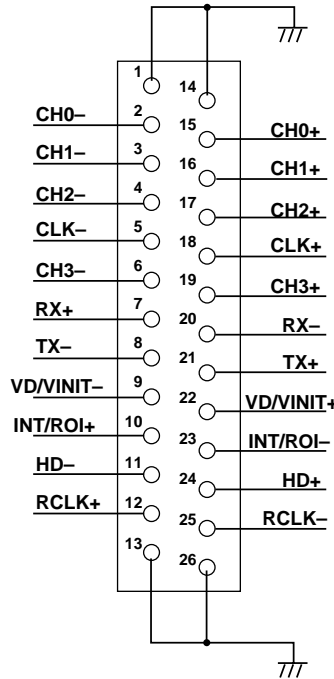

#### Node description:

- CH0:** Data B0, A5, A4, A3, A2, A1, A0
- CH1:** Data C1, C0, B5, B4, B3, B2, B1
- CH2:** Data DVAL, FVAL, LVAL, C5, C4, C3, C2
- CH3:** Data SPARE, C7, C6, B7, B6, A7, A6
- CLK:** Data clock
- RX, TX:** Serial communication, RX = Ser to Cam  
TX = Ser to FG
- VD/VINIT:** Ext. VD in or VINIT (Trigger) in
- INT/ROI:** Integration control in or Read-Out-Inhibit in
- HD:** External HD in
- RCLK:** External read clock in

\* HD, VD for external sync input. (Please contact PULNiX for Ext. HD input)

\*\* RCLK is reserved for read clock input.

### Camera Link Signal Assignment to Channel Link Chip (RGB 8-bit x 3)

Tx IN0	Data R0 (LSB)	Tx IN8	G1	Tx IN16	B6	Tx IN24	LDV
Tx IN1	Data R1	Tx IN9	G2	Tx IN17	B7	Tx IN25	FDV
Tx IN2	Data R2	Tx IN10	G6	Tx IN18	B1	Tx IN26	LPULSE
Tx IN3	Data R3	Tx IN11	G7	Tx IN19	B2	Tx IN27	R6
Tx IN4	Data R4	Tx IN12	G3	Tx IN20	B3	Tx CLK	Data clock
Tx IN5	Data R7 (MSB)	Tx IN13	G4	Tx IN21	B4		
Tx IN6	Data R5	Tx IN14	G5	Tx IN22	B5		
Tx IN7	Data G0	Tx IN15	B0	Tx IN23	(YCC CLK)		

**Note1:** CLK: data clock, LDV: Line data valid, FDV: Frame data valid, INTEG: Integration control, VINIT: Async Trigger Input, ROI: Read-out-inhibit.

**Note2:** Data R<sub>0-7</sub> is defined as A<sub>0-7</sub>, Data G<sub>0-7</sub> is defined as B<sub>0-7</sub>. Data B<sub>0-7</sub> is defined as C<sub>0-7</sub>. For 8-bit B/W, only A<sub>0-7</sub> is used. For 8-bit x 2 A<sub>0-7</sub> and B<sub>0-7</sub> are used.

**Note3:** Camera control via 12-pin connector (RS-232) is available as an option.

# Camera Link Camera Models



Camera models B/W Cameras	CCD (in)	Resolution	Frame rate (frame/sec)	Data Clock (MHz)	Data	Analog video	Size (HxWxL mm)
TM-6763CL	1/3	648 x 484	60/30	25.49/12.75	Ch-A 8-bit	BNC:VGA video	44 x 44 x 64
TM-6760CL	1/2	648 x 484	60/30	25.49/12.75	Ch-A 8-bit	BNC:VGA video	44 x 44 x 64
TM-6710CL	1/2	648 x 484	120/60	25.49/12.75	Ch-A & B, 8-bit x 2	BNC:120 fps @50MHz	39 x 46 x 140
TM-1400CL	1/2	1392 x 1040	20	33.3	Ch-A 8-bit	BNC:progressive scan	44 x 44 x 64
TM-9720CL	2/3	768 x 494	30	14.18	Ch-A 8-bit	BNC:progressive scan	44 x 44 x 64
TM-1320-15CL	2/3	1300 x 1030	15	25.0	Ch-A 8-bit	BNC:progressive scan	44 x 44 x 64
TM-1320-24CL	2/3	1300 x 1030	24	40.0	Ch-A 8-bit	BNC:progressive scan	44 x 44 x 64
TM-1325-18CL	2/3	1392 x 1040	18	33.3	Ch-A 8-bit	BNC:progressive scan	44 x 44 x 64
TM-1020-15CL	1	1008 x 1018	15	20.0	Ch-A 8-bit	BNC:progressive scan	44 x 44 x 64
TM-1020-25CL	1	1008 x 1018	25	33.3	Ch-A 8-bit	BNC:progressive scan	44 x 44 x 64
TM-1020-30CL	1	1008 x 1018	30	40.0	Ch-A 8-bit	BNC:progressive scan	44 x 44 x 64
TM-2016-8CL	1	1920 x 1080	8	20.0	Ch-A 8-bit	BNC:progressive scan	44 x 44 x 64
TM-2016-15CL	1	1920 x 1080	15	40.0	Ch-A 8-bit	BNC:progressive scan	44 x 44 x 64
TM-2020-8CL	1	1608 x 1200	8	20.0	Ch-A 8-bit	BNC:progressive scan	44 x 44 x 64
TM-2020-15CL	1	1608 x 1200	15	40.0	Ch-A 8-bit	BNC:progressive scan	44 x 44 x 64
PC-640CL	1/3 C-MOS	640 x 480	60/30	20/10	Ch-A 8-bit	—	44 x 44 x 37
PC-1024CL*	1 C-MOS	1024 x 1024	500	66.6	8 Ch x 8-bit	—	60 x 70 x 40
<b>Color Cameras</b>							
TMC-6700CL	1/2	648 x 484	60	25.49	Ch-R,G,B: 8-bit x 3	Dsub:RGB video VGA video	51 x 67 x 117
TMC-1000CL	1	1008 x 1018	15	20.0	Ch-R,G,B: 8-bit x 3	Dsub:RGB video Progressive scan	51 x 67 x 117
TMC-9700CL*	2/3	768 x 484	30	14.318	Ch-R,G,B: 8-bit x 3	Dsub:RGB(NTSC) video	46 x 51 x 162
TMC-6763CL <sup>Δ</sup>	1/3	648 x 484	60	25.49/12.75	Ch-A 8-bit	BNC:VGA video	44 x 44 x 64
TMC-6760CL <sup>Δ</sup>	1/2	648 x 484	60	25.49/12.75	Ch-A 8-bit	BNC:VGA video	44 x 44 x 64
TMC-6710CL <sup>Δ</sup>	1/2	648 x 484	120	25.49	Ch-A & B, 8-bit x 2	BNC:120 fps @50MHz VGA video	39 x 46 x 140
TMC-1400CL <sup>Δ</sup>	1/2	1392 x 1040	20	33.3	Ch-A 8-bit	BNC:progressive scan	44 x 44 x 64
TMC-1320-15CL <sup>Δ</sup>	2/3	1300 x 1030	15	25.0	Ch-A 8-bit	BNC:progressive scan	44 x 44 x 64
TMC-1320-24CL <sup>Δ</sup>	2/3	1300 x 1030	24	40.0	Ch-A 8-bit	BNC:progressive scan	44 x 44 x 64
TMC-1325-18CL <sup>Δ</sup>	2/3	1392 x 1040	18	33.3	Ch-A 8-bit	BNC:progressive scan	44 x 44 x 64
TMC-1020-15CL <sup>Δ</sup>	1	1008 x 1018	15	20.0	Ch-A 8-bit	BNC:progressive scan	44 x 44 x 64
TMC-2016-8CL <sup>Δ</sup>	1	1920 x 1080	8	20.0	Ch-A 8-bit	BNC:progressive scan	44 x 44 x 64
TMC-2020-8CL <sup>Δ</sup>	1	1608 x 1200	8	20.0	Ch-A 8-bit	BNC:progressive scan	44 x 44 x 64

\* Planned      <sup>Δ</sup> AccuPIXEL color cameras require software interpolation.

Release timing of models may vary. Please contact PULNiX for availability.  
For detailed camera specifications, please refer to the standard camera data sheet for each model.

Camera Link

[07/19/2002] 71-0048 Rev.A

**Japan**  
PULNiX America, Inc.  
1-11-14 Hongo Bunkyo-ku,  
Tokyo 113-0033  
Tel: 81-3-5805-2455  
Fax: 81-3-5805-8082  
www.pulnix.co.jp

**Australia**  
PULNiX America, Inc.  
16 / 35 Garden Road  
Clayton, VIC 3168  
Tel: 61-(0)3-9546-0222  
Fax: 61-(0)3-9562-4892  
Email:  
pulnix@ozemail.com.au

**United Kingdom**  
PULNiX Europe, Ltd.  
PULNiX House,  
Aviary Court, Wade Road  
Basingstoke, Hampshire  
RG24 8PE  
Tel: 44(0)1256-475555  
Fax: 44(0)1256-466268  
www.pulnix.eu.com

**Germany**  
PULNiX Deutschland, GmbH.  
Siemensstrasse 12  
D-63755 Alzenau  
Tel: 49(0)6023-9625-0  
Fax: 49(0)6023-9625-11  
www.pulnix.de



**PULNiX**

*Innovation at work!*

**PULNiX America, Inc.**      **Tel: 408-747-0300**  
**1330 Orleans Drive**      **Tel: 800-445-5444**  
**Sunnyvale, CA 94089**      **Fax: 408-747-0660**